

CAMERA WASH™

Additional Nozzle

U.S. Patents 6,554,210 & 6,199,773



MSF8470038000A

INSTALLATION GUIDE

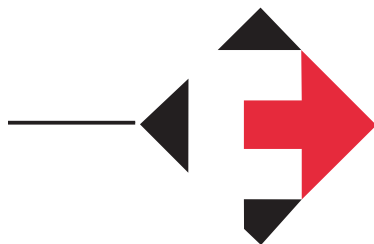

Another Convenience Product from

M. S. Foster & Associates

1866 N. Country Lane, Michigan City, IN 46360
Phone 219-879-9225 • Toll Free 888-452-4053
Fax 219-879-9313 • email: sales@msfoster.com
www.msfoster.com

2

1

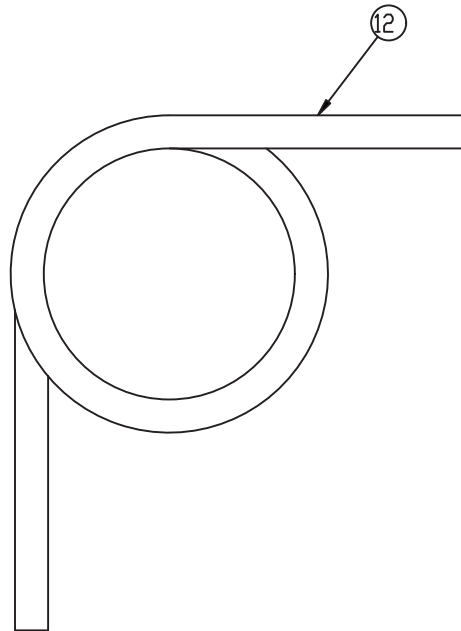
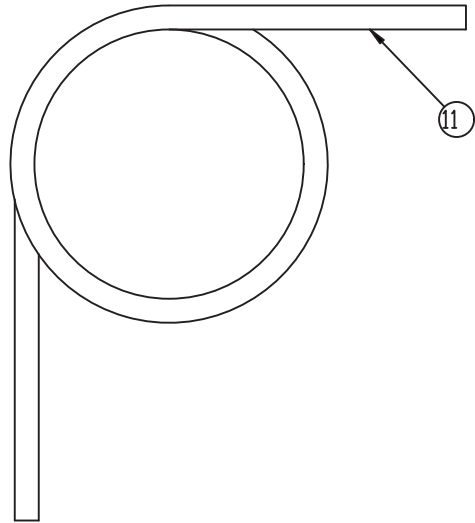
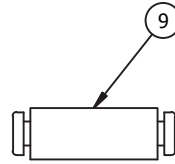
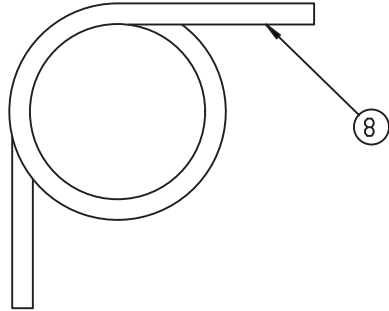
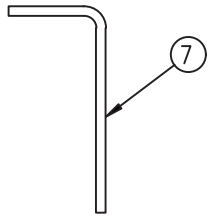
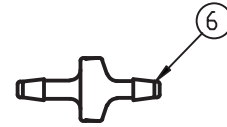
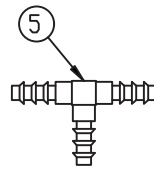
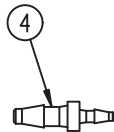
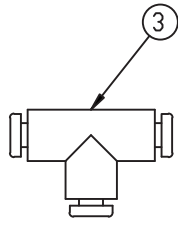
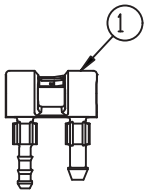

PARTS LIST			
ITEM	QTY	PART NUMBER	DESCRIPTION
1	1	MSF847-0026-000	CameraWash Nozzle
2	2	MSF027-0003-003	CameraWash Retainer
3	1	MSFKV2T07-00	SMC 1/4" Push To Connect T-Fitting
4	1	MSFW-538	Fitting, Reducer 5/32" to 3/32"
5	1	MSFW-344-1	"T" Hose Fitting
6	1	MSFW-634	Check Valve - In-Line
7	1	MSF5174	S.S. Nozzle Holder Bracket
8	1	MSF9776T2	3/32" Tubing x 12" Lg.
9	1	MSFKV2H07-00	1/4" Straight Union
11	18 FT	1A-223-01	1/4" DOT Nylon Tubing
12	18 FT	MSFTH-3340250	5/32" Windshield Wiper/Vacuum Tubing
13	1	INSTRUCTION	CameraWash Installation Instructions

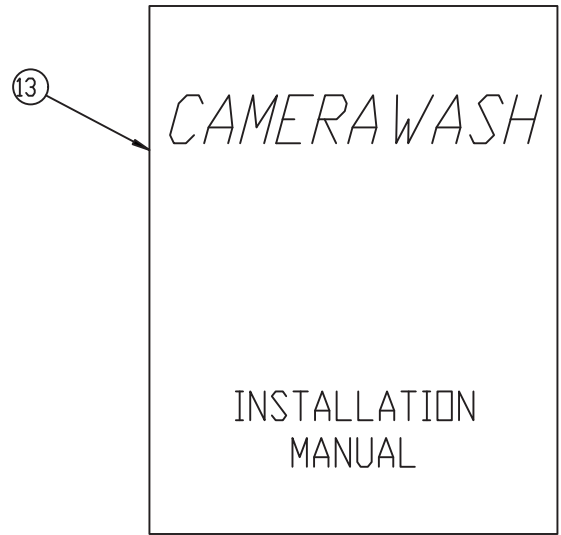

DRAWN Ryan Kitkowski	8/17/2013	 M. S. Foster & Associates 1844 N. Country Lane, Michigan City, IN 46340 Phone 219-475-7223 • Toll Free 888-425-4053 Fax 219-929-9513 • email: sales@mufoster.com www.mufoster.com
CHECKED Mark Hubertz		
MFG		
APPROVED Michael Foster		
		TITLE CAMERA WASH ADDITIONAL NOZZLE KIT ASSEMBLY
SIZE A		DWG NO MSF847-0038-000A
SCALE		REV A

2

1

B

B

A

A

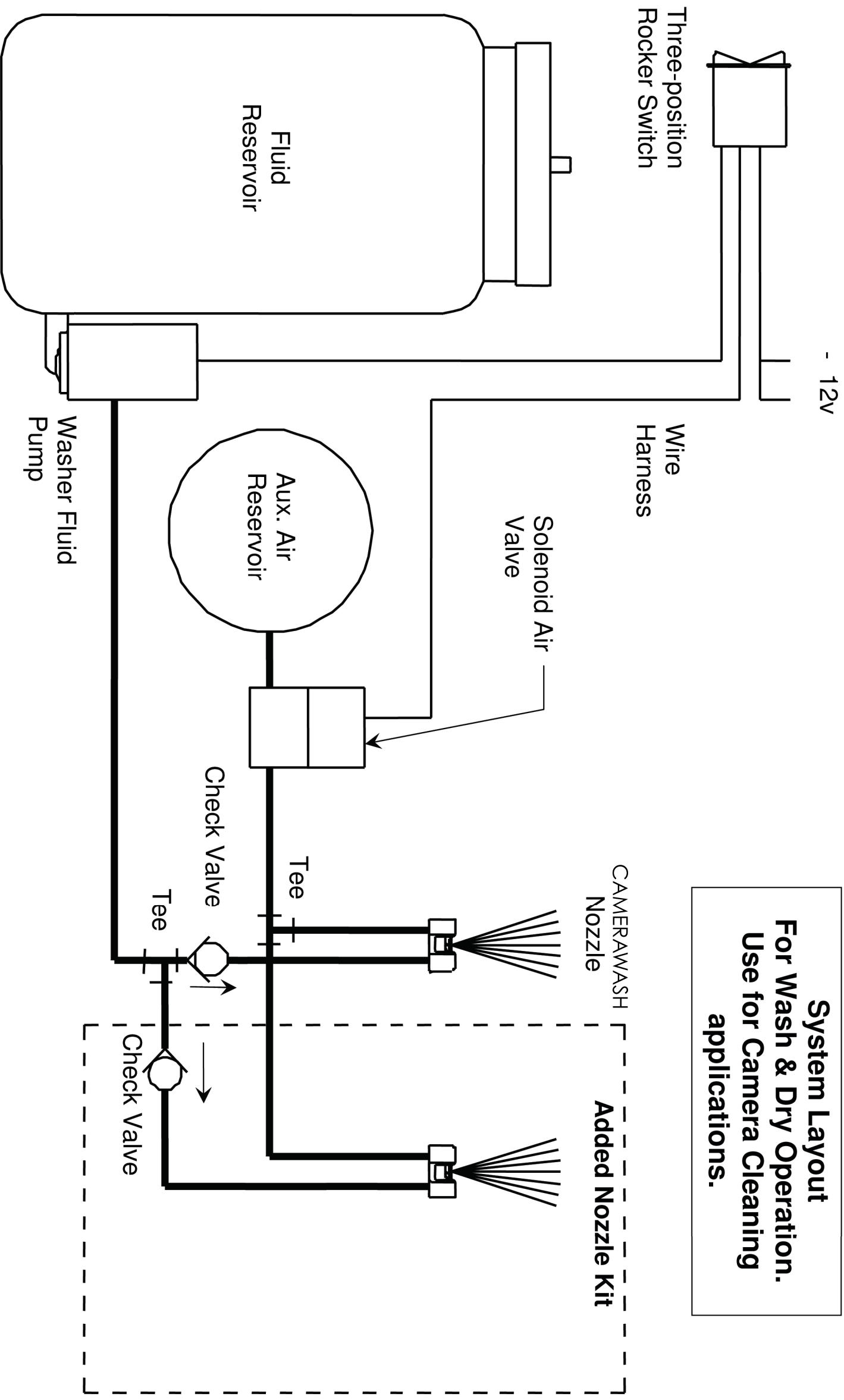

**System Layout
For Wash & Dry Operation.
Use for Camera Cleaning
applications.**

Installation Instructions CAMERAWASH™ – Additional Nozzle

These instructions describe the installation of an additional Nozzle to a CAMERAWASH system. Up to four (4) Nozzles may be used with each Pump and Solenoid pair.

- Step 1. Cut into the air and fluid delivery lines from the Reservoir and Solenoid that go to the first Nozzle and insert the appropriate tee fittings. Make sure that the fluid line splice is into the larger (5/32" I.D.) rubber tubing and not the smaller tubing.
- Step 2. Route the air and fluid delivery lines from the tees to the additional Nozzle location. Avoid sharp edges and kinks. Route so as to avoid tubing damage in normal use.
- Step 3. Locate the Nozzles as instructed in the CameraWash kit instructions.
- Step 4. **Nozzle Location:** The Nozzles can be aimed up, down, or sideways. The primary consideration is to have the Nozzle within 4 inches of the lens, and 1" to 2" ahead of it.
- Step 5. **Nozzle Adjustment:** The Nozzle spray direction is adjustable over 125°. Pre-adjust the Nozzle before installing to spray in the direction needed. Always use a 5/16" wide, flat head screwdriver (in good condition) to adjust the Nozzles. Hold the Nozzle securely, against a solid surface and turn slowly, applying generous downward force to prevent the bit from slipping out of the slot.

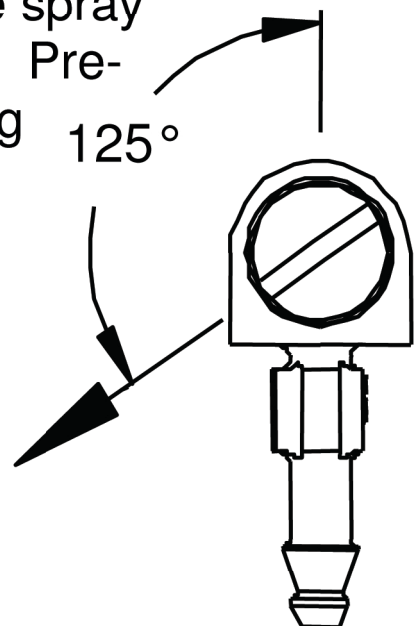

Installation Instructions CAMERAWASH™ – Additional Nozzle

- Step 6. Insert the Nozzles into the nozzle bracket. Position the Nozzles so that the fluid and air outlets are facing the camera. You may need to access the adjustment slot later, so make sure it is easily accessible.

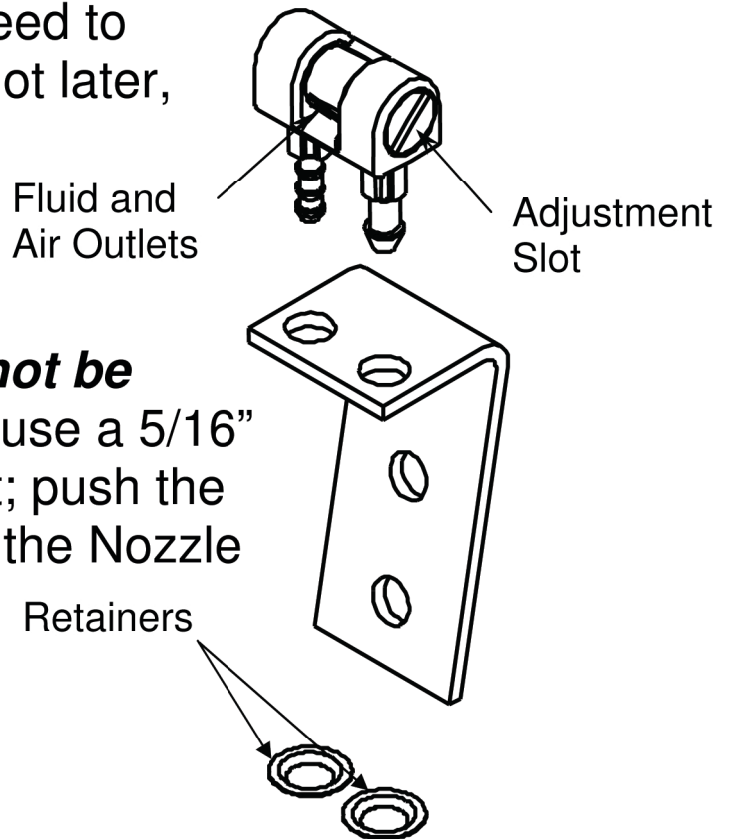

Once the Retainers are installed, they cannot be reused. To install them use a 5/16" or 8mm hex deep socket; push the Retaining Washers onto the Nozzle hose barbs until the Nozzle fits snugly onto the bracket.

- Step 7. Install the 18" piece of 3/32" ID rubber Tubing to the Nozzle fluid fitting. (The fluid fitting has three barbs.) Attach the nylon Tubing to the Nozzle air fitting. The air fitting is shorter, has one single barb, and is label "AIR". Check to make sure that the air and fluid lines are connected to the correct barbs. Install the Check Valve between the small rubber tubing to the nozzle and the larger rubber tubing from the pump. Make sure the arrow is pointing away from the Pump.

Nozzle Attachment

NOTE: If more tubing is needed, use .156" (5/32") I.D. Windshield Washer Tubing for the rubber tubing and use 1/4" O.D. SAE J844 Nylon tubing for the air lines.

- Step 8. Attach the bracket to the vehicle.
- Step 9. Install the Check Valve near the Nozzle. Make sure the arrow points toward the Nozzle.