

Voyager® WVOS511

Wireless Observation System

No Wires
or Cables!



FEATURING
WiSight™ technology



KEY FEATURES:

- Easy Installation, fits most applications
- 5.6" Monitor comes with suction cup mount and 12 Volt DC plug for easy portability
- Camera connects to rear clearance lights
- WiSight technology - No cables or wiring necessary
- No interference
- Signal transmits through and around objects up to 60+ feet away
- Sharp, clear, uninterrupted picture

OBSERVATION
SYSTEMS



M. S. Foster & Associates

1866 N. Country Lane, Michigan City, IN 46360
Phone 219-879-9225 • Toll Free 888-452-4053
Fax 219-879-9313 • email: sales@msfoster.com
www.msfoster.com

EXPAND your vision™

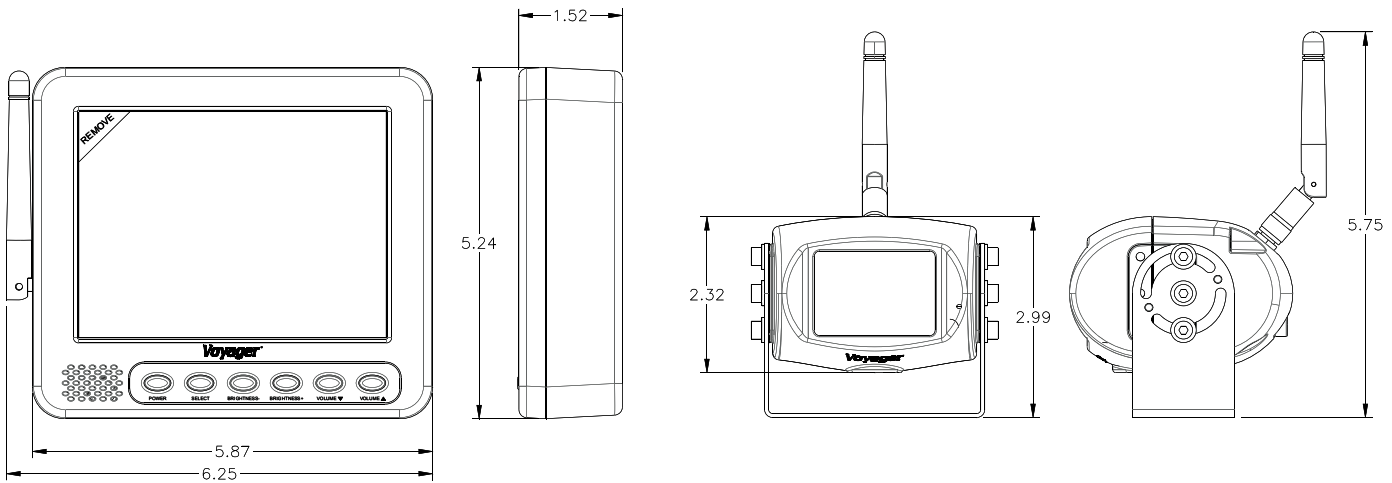

Specifications	CAMERA	MONITOR
Power System	12VDC	12VDC
Operating Voltage Range	10 ~14V	10 ~ 14V
Power Consumption (MAX)	300mA	630mA
Operating Temperature Range	-4°F to 149°F	-4°F to 149°F
Storage Temperature Range	-40°F to 185°F	-40°F to 185°F
Operating Relative Humidity	100%	95%
Waterproof Rating	IPX6	NA
Overall Dimensions	3"x 5.8"	1.5"x 5.2" x 6.3"
Product Weight (unpackaged)	13 oz	14 oz
Video Output Signal Format	NTSC	NTSC
Video Signal Level	1.0V p-p ; 75Ω	1.0V p-p ; 75Ω
Audio	Microphone	1.5 watt
Sensor	1/3" CMOS	NA
Sensitivity	0 Lux	NA
Image Orientation	Mirror (Reversed)	NA
Resolution	420 Lines	960(W) x 234(H)
View Angles	117°(D) 93°(H) 66°(V)	100°(H) 80°(V)
Brightness	NA	500 nit
Contrast Ratio	NA	250:1
Response Time	NA	30ms(R) 40ms(F)
Display Format	NA	4:3