



ROTOGRIP[®]

Complete Instructions for Classic system

For

Rotating Chains

With pneumatic swiveling mechanism

Installation Instructions

- ① Chain wheel
- ② Swing arm
- ③ Cylinder
- ④ Universal adapter
- ⑤ Mounting components (specific to type of vehicle)

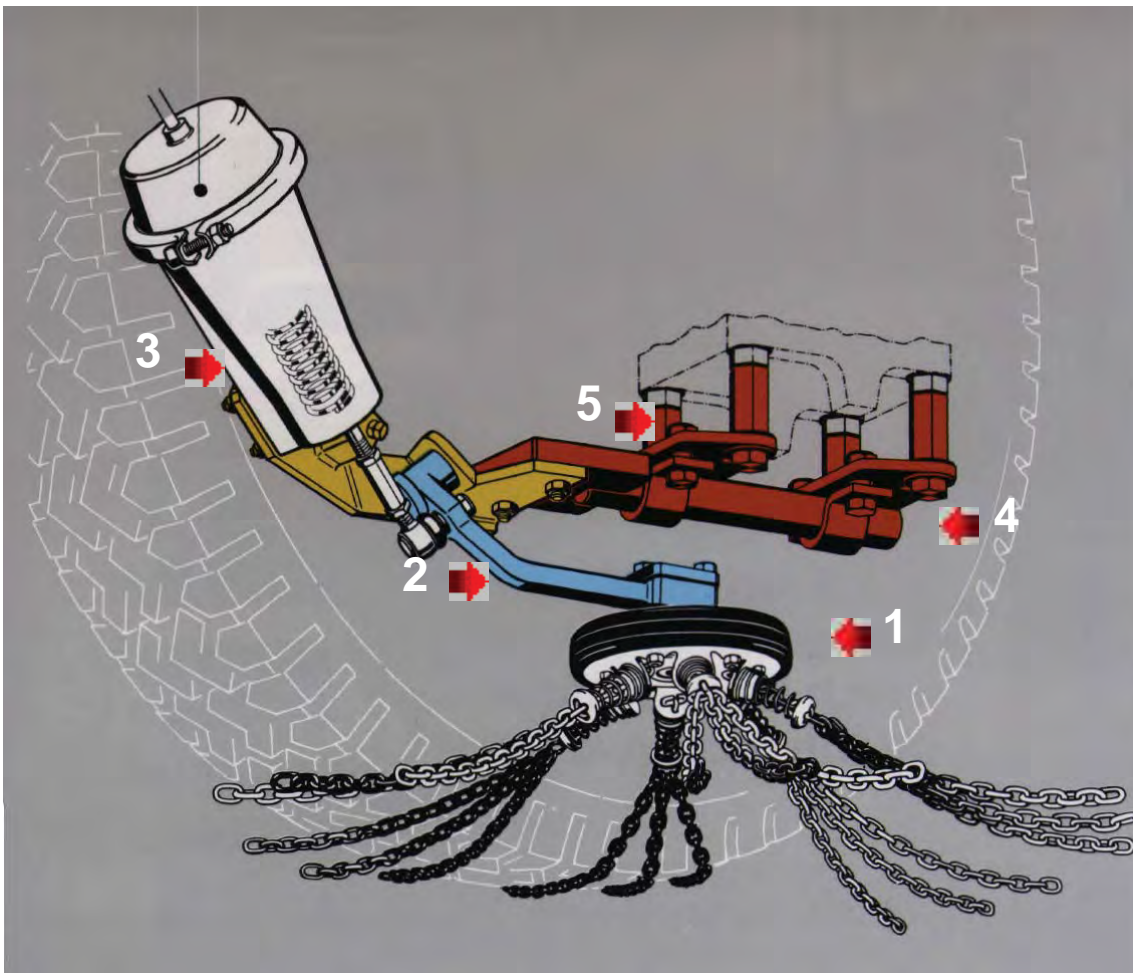

Installation Instructions

Description

RUD rotating chains essentially consist of three sub-assemblies. These can be simply installed on the vehicle with the aid of the accompanying Installation Instructions.

I. Mounting components (specific to vehicle type)

Mounting points are determined by the specific vehicle design or suspension. In many cases, the system will be mounted on the vehicle's U-bolts with the extension nuts threaded on below the original U-bolt nuts. **Be sure to follow manufacturer's recommendation when replacing and re-torquing U-bolts.** *RUD extension nuts should not be used as a replacement for U-bolt nuts.*

II. Universal Adapter

This consists of two adapter plates per vehicle side. The mounting tube is attached to the adapter plates by clamps to form a rigid unit.

The mounting plate welded to the mounting tube holds the swiveling assembly securely in position.

III. Swiveling assembly

The swiveling assembly consists of a pneumatic cylinder with swinging arm and chain wheel.

IV. Pneumatic equipment

The pneumatic equipment is included in set (part) no. 68000.

To install, proceed as in the illustrated sheet.

Installation Instructions

Rotating chains must be installed in such a way that no weight-bearing parts of the vehicle are weakened. Brake lines, cables etc. within the swiveling range of the chains must not be put at risk.

INSTALLATION

IMPORTANT!

1. With a piece of chalk, mark the point of contact of the chain wheel on the sidewall of the tire. With the vehicle unloaded, this should be approximately 3-1/2" (small chain wheel) or approximately 4" (large chain wheel) above the road surface and at the **vertical center** of the tire. Be sure to use a plumb bob, water, steel ball, or tape measure to find center.

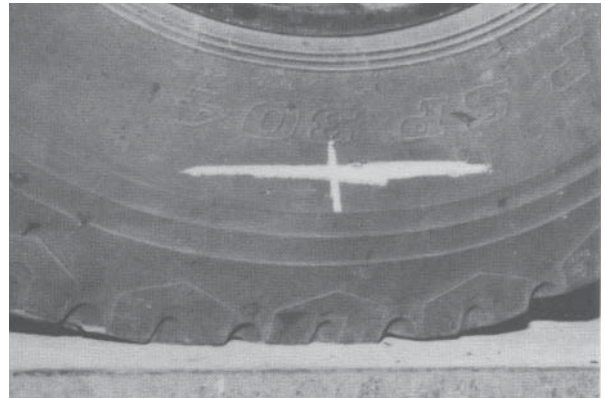

2. With the specific vehicle mounting components, install universal adapter nuts first. Then measure from the ground to the bottom of the adapter nuts. Take a look at Fitment 1 thru 5 in the middle of the packet. Then you can use the shims to adjust the system. Next, you will need to put the two adapter plates with the slots towards the center of the truck, and use the hole closest to the slot to keep the mount closer to the tire when possible.

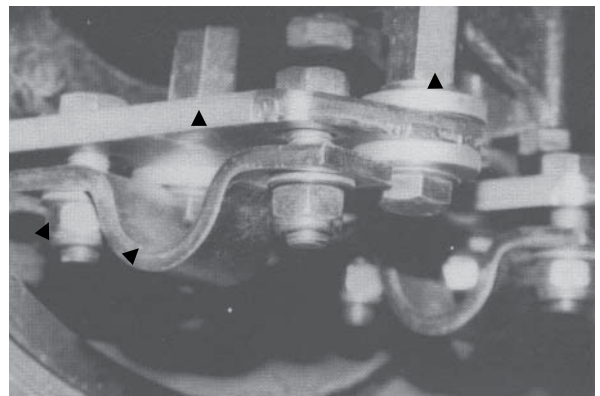

Adapter
Plate

Adapter
Nut

3. Install tube clamps on adapter plates. Leave Bolts and lock nuts finger-tight at this stage.

Installation Instructions

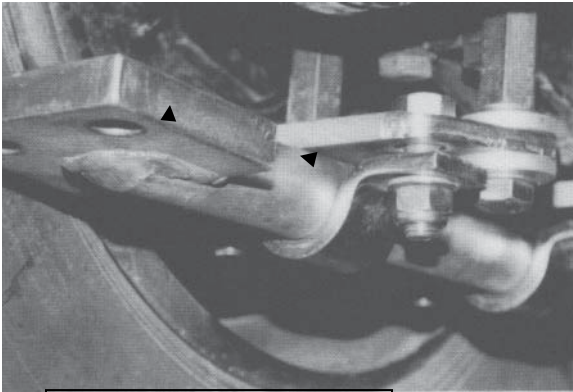

**4 deg. angle on tube
needs to be up**

4. Introduce mounting tube into clamps as shown in diagram. Make sure angle on the tube is up.

Mounting tube

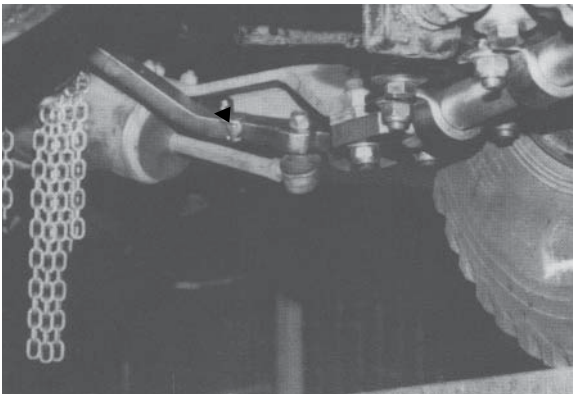

5. Place cylinder unit, with pre-installed swinging arm, on mounting plate.

Cylinder Unit

6. Adjust mounting tube relative to cylinder in accordance with dimensions. Further, tighten clamp bolts slightly.

Ball Stud

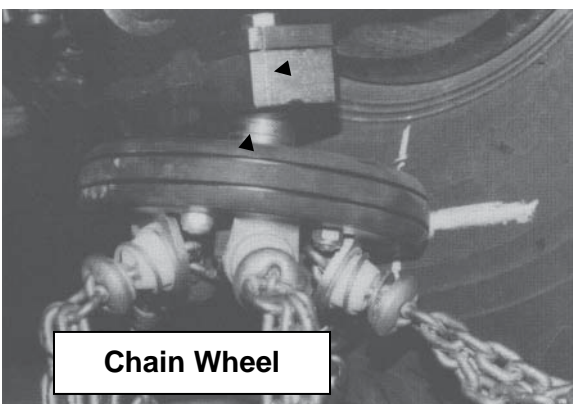

Chain Wheel

7. Place chain wheel on ball stud of swinging arm. Tighten nuts finger-tight. Run air into system so that you can move the swing arm. Move chain wheel onto tire by air and locate in operational position, the wheel must be horizontal to the direction of travel and inclined approximately 5 – 10° to the tire.

Installation Instructions

8. Now tighten ball housing cap screws to 45 ft. lb. Securely tighten pin locating set screw (front of ball housing).

Tighten lock nuts on mounting tube clamps to 135 ft. lb.

9. In the swiveling process, the distance between the chain wheel and drive shaft must not be less than 3/8". It is permissible, however, for the axle housing to be touched slightly through the spring action of the chain disc in its return to an inoperative position).

- ! 10. If necessary, minor adjustments can be carried out with regard to the dimensional data **keep in mind that correct chain wheel position (center of axle) is of utmost importance to the operation and life of the system and components.**

11. Tighten all bolts (16mm) on the universal adapter components to the required torque (135 ft. lb.).

12. When the vehicle is loaded, the chains should hang clear of the ground by 1/2" when in the stored position. If necessary, adjust the end-stop or shorten the ends of the chains.

13. Recheck that all fasteners are tightened to the specified torque.

WARNING –

Keep away from swing arm travel path! Serious injury or death can result if struck when system is activated or de-activated. **DO NOT** allow yourself or others to be put at risk!

Fastener Torques

Ball stud housing screws –
45ft/lb.

Chain wheel lock nut – 100 ft. /lb.

All 16mm bolts – 135 ft. /lb.

Extension nuts -135 ft. /lb.

Use manufacturer's recommendation for U-bolts torque.

Installation Instructions

Direction of travel *



1" Approximately Starting Point

System is designed for front of the axle mounting but can be mounted to the rear if needed. Next page will show more options for Mounting.

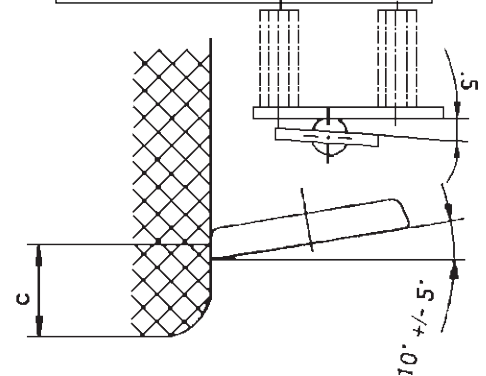
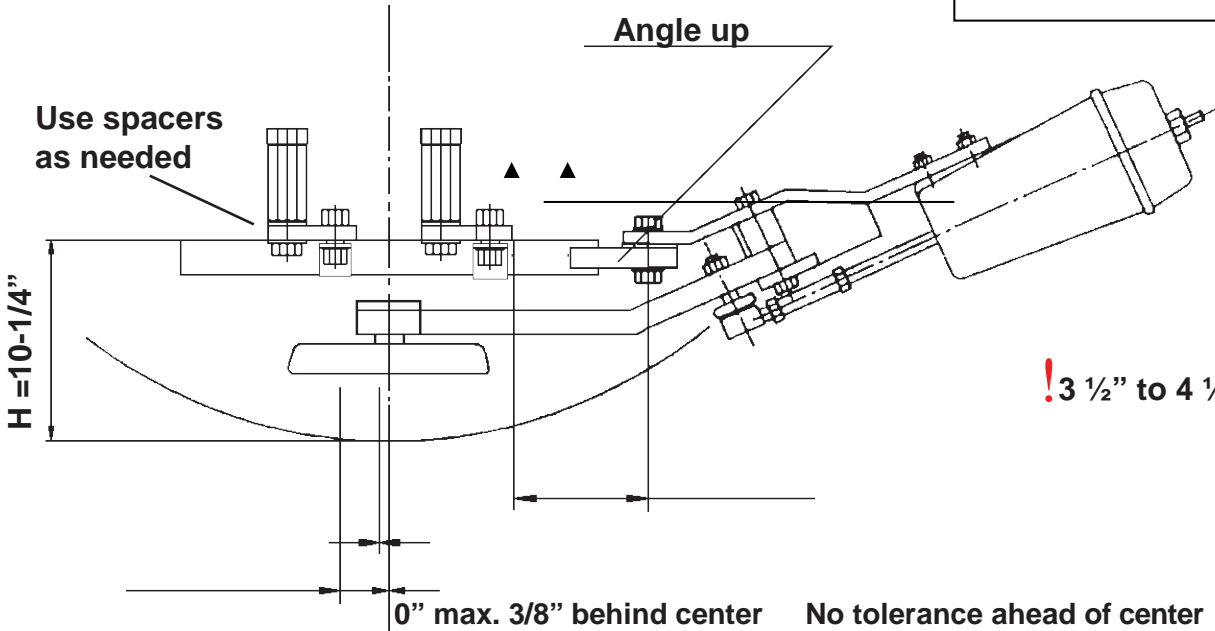

Tire

Keep Air Cylinder pulled towards the tire or outside of the truck.

Angle Up

Use hole closest to the slot to keep the plates closer to the tire

Clamp Holes

Extension Nuts (U-Bolts)

Fitment 2
System on top tube on
bottom

Installation Instructions

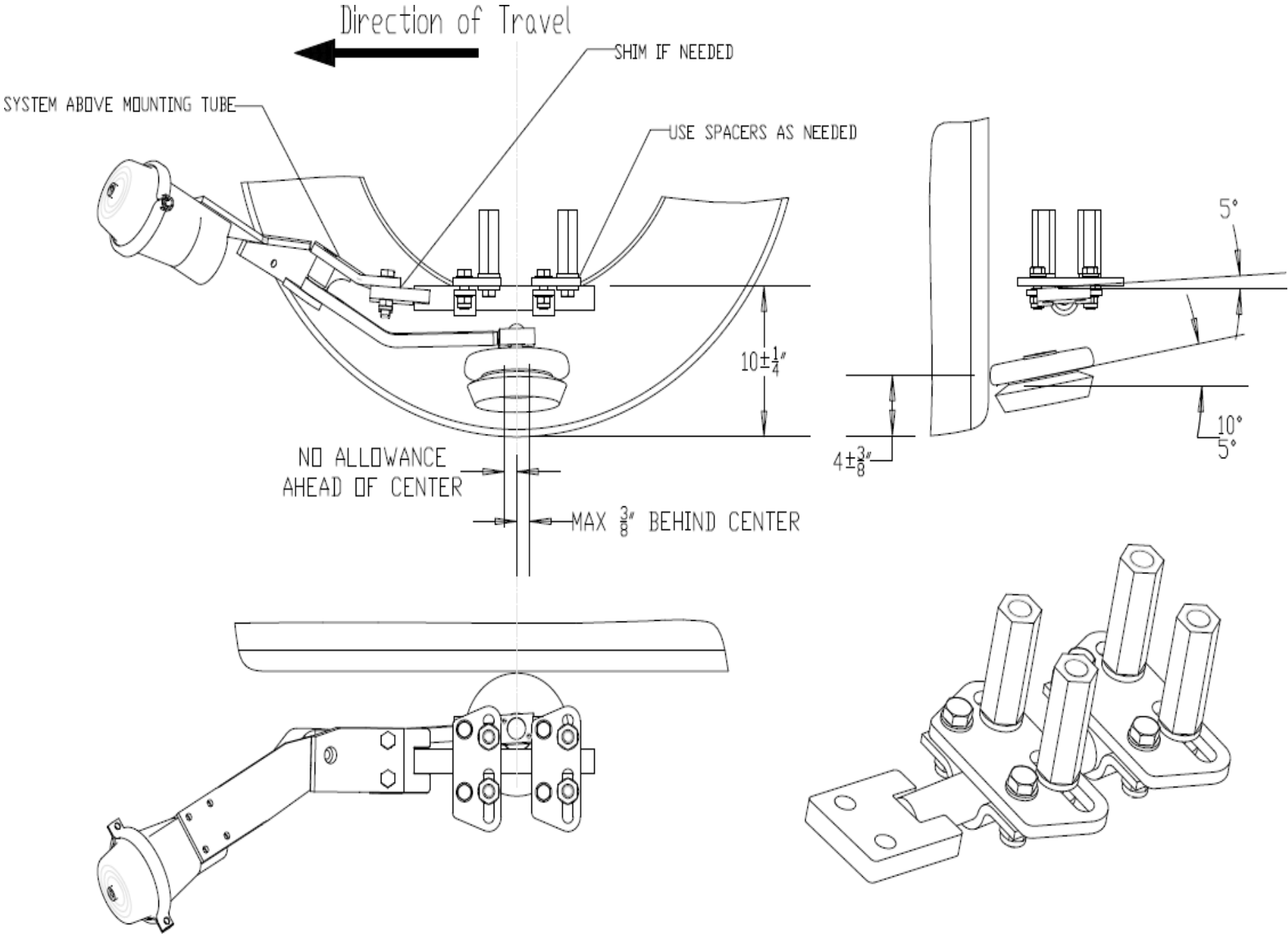

Installation Instructions

Fitment 3
System on bottom tube on
bottom

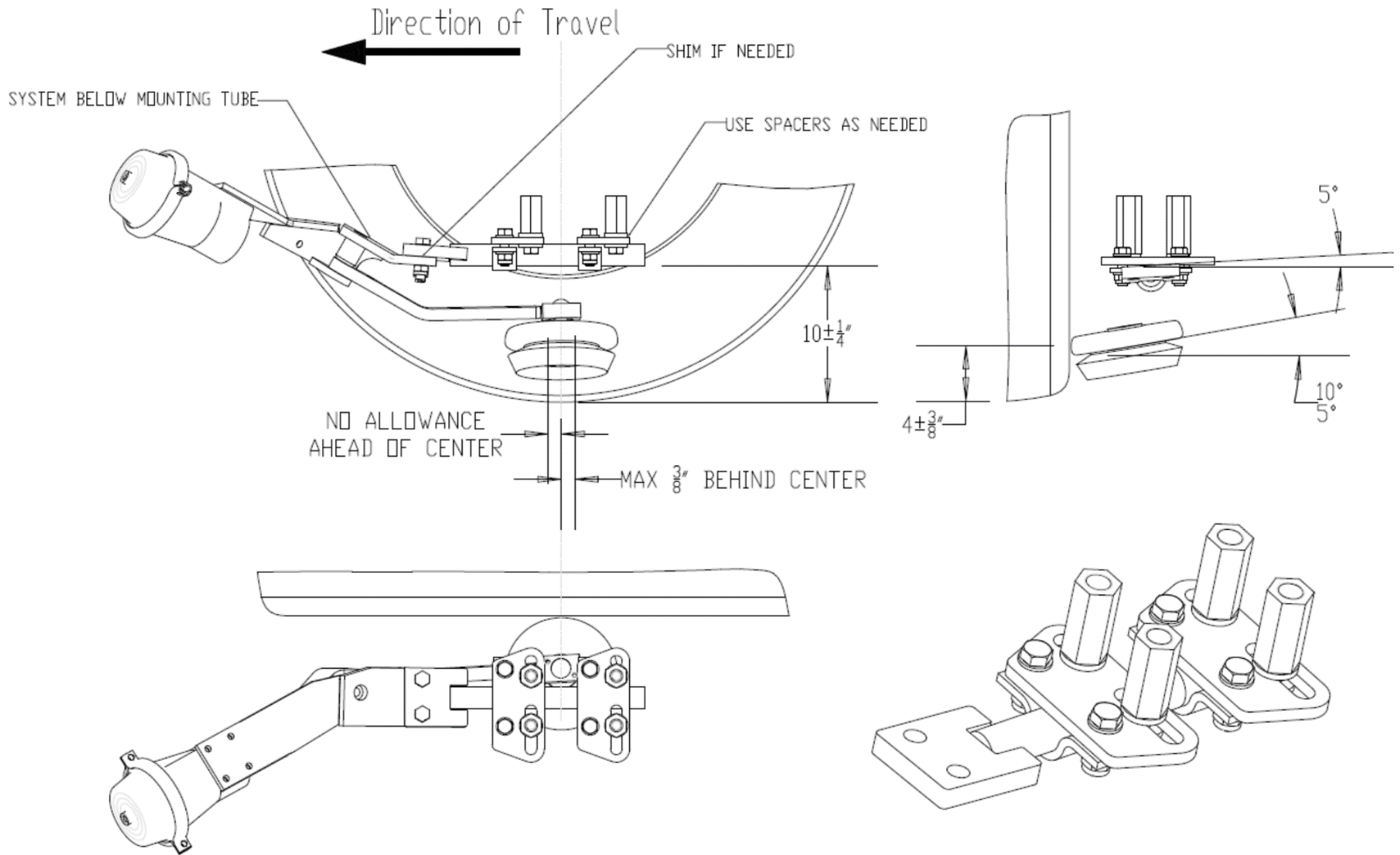

Installation Instructions

Fitment 4
System on bottom with
tube on top

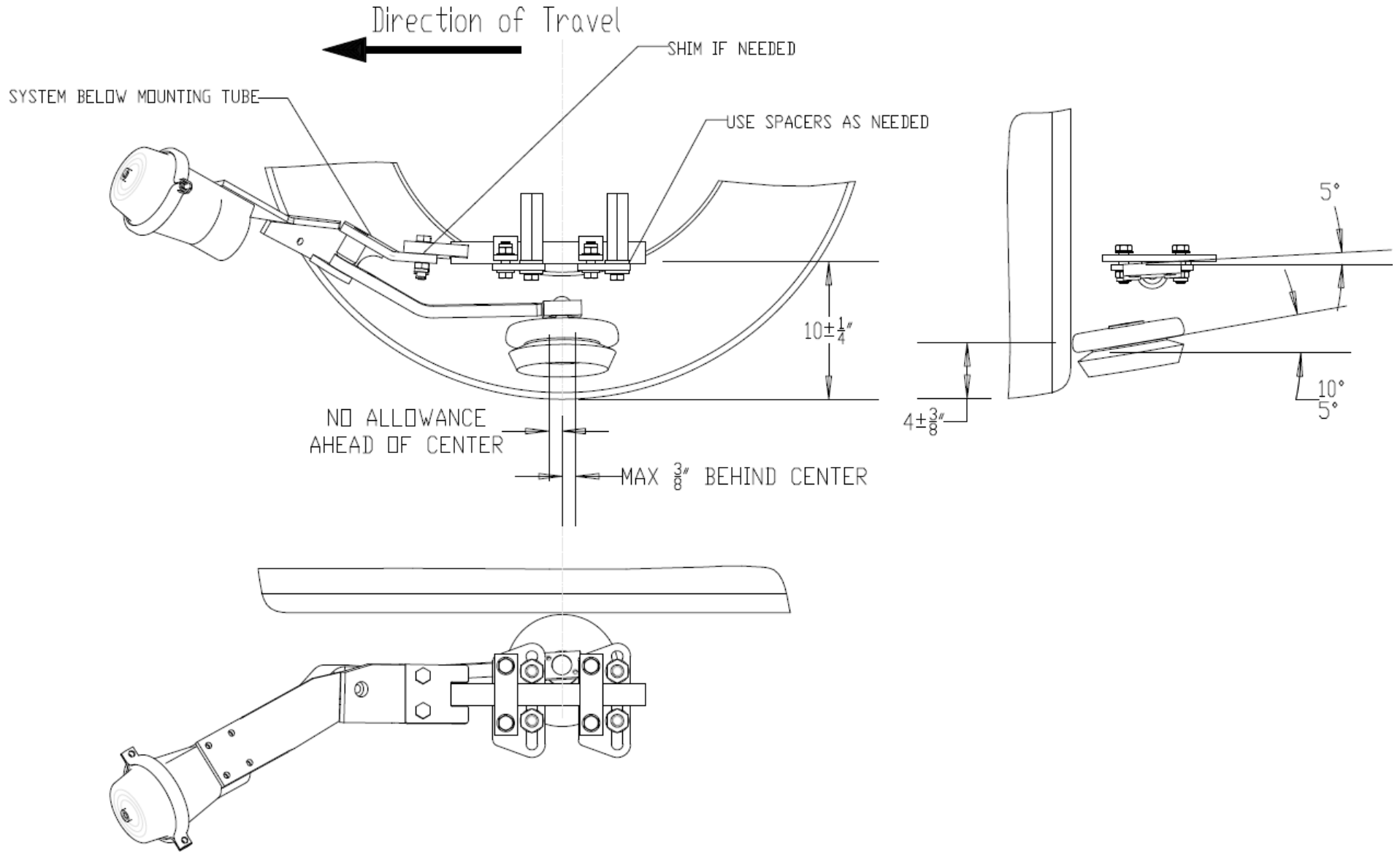

Fitment 5
System on top with tube on top

Installation Instructions

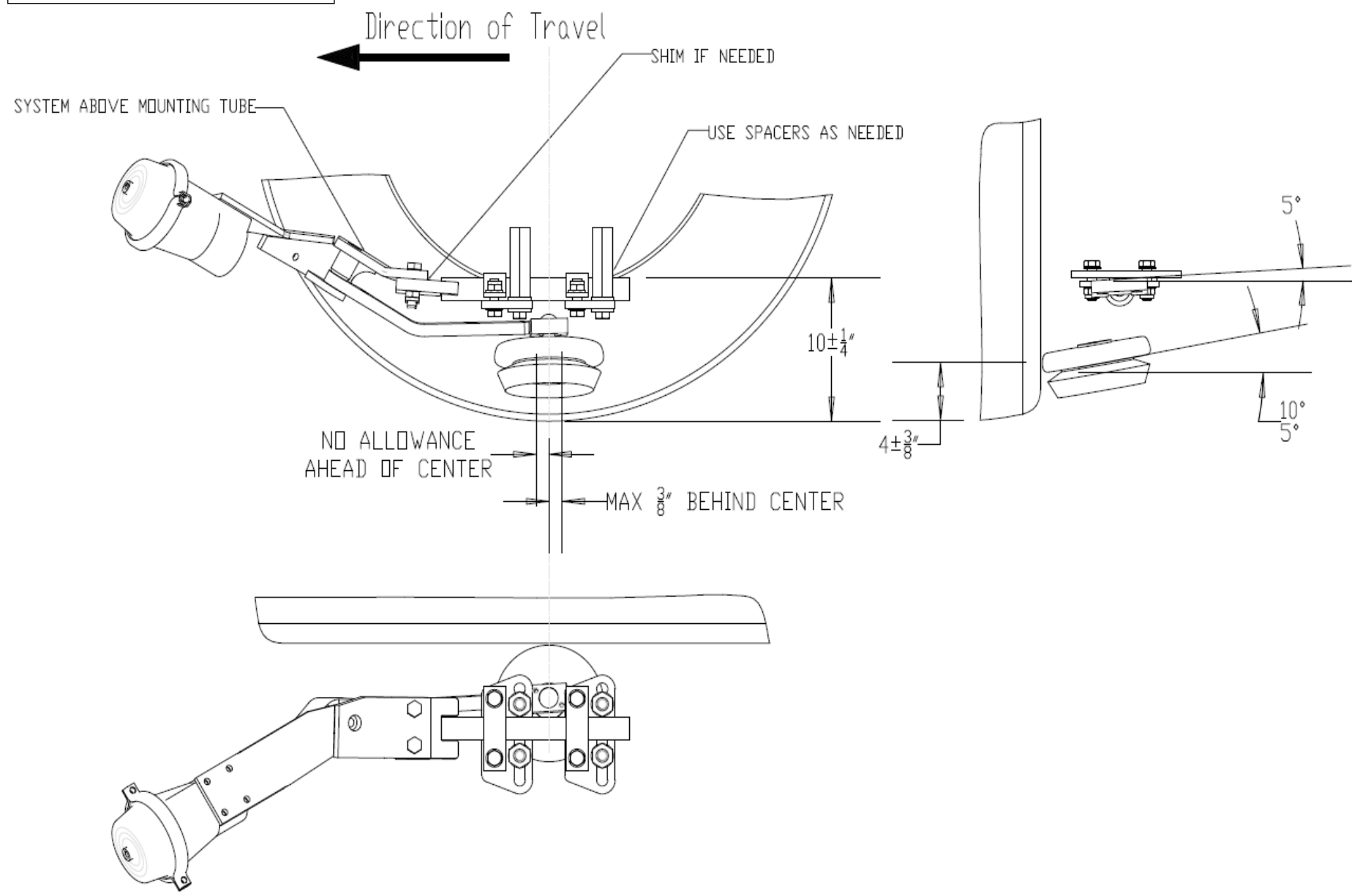

Installation Instructions

Installing Airline and Solenoid



Metric adapter fitting

90-degree Air fitting

1. You will need to put the Metric adapter fitting in the back of the air cylinder and then you can put the compression 90-degree 3/8 air fitting into the metric adapter.

Airline



Power wire, which will need to be, ran from the solenoid to the cab behind the dash

T fitting, This is also the outlet port for air

90-degree air fitting, This is also the inlet port for the air

2. Next, you will need to find a safe and secure place to mount the solenoid. It is best to put it somewhere between your systems and the air tank in the cross frame. Once you find a spot put the T fitting in the side of the solenoid, which is the outlet, and the 90-degree fitting at the top, which is the inlet. Make sure the arrow on the solenoids pointing up.

Installation Instructions

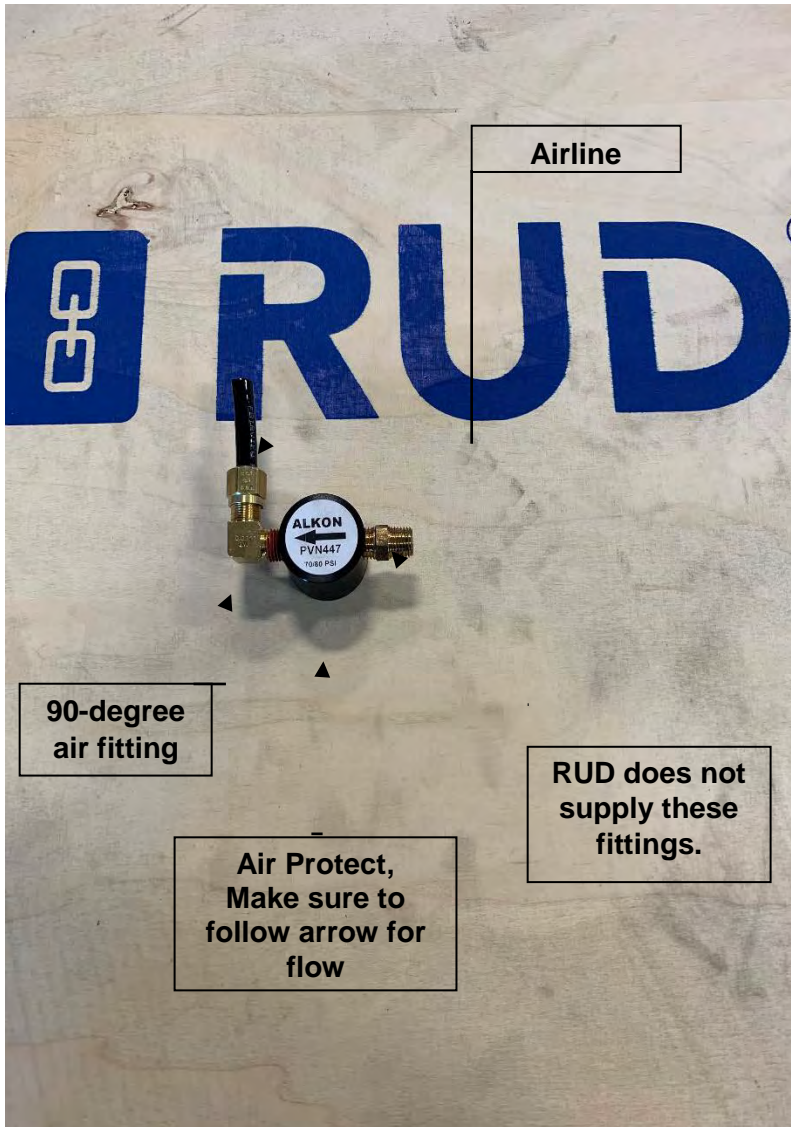

3. Next, you need to find an air supply. When looking for the air supply find a free port in your air tank. Install the air protect valve at the air tank port. Make sure that the airflow arrow is pointed away from the supply tank, Now install the airline from the supply side of the solenoid to the air protect valve. Keep the airline in the frame rail so it is out of the way and cannot be caught.
4. Now you can run the airlines from the air cylinder through the frame rails to the solenoid. Make sure you hook the air to the T fitting so you have supply to both systems. Remember when running the airline leave enough slack so when the axle travels up and down the airline will not pull or break any fittings.

Installation Instructions

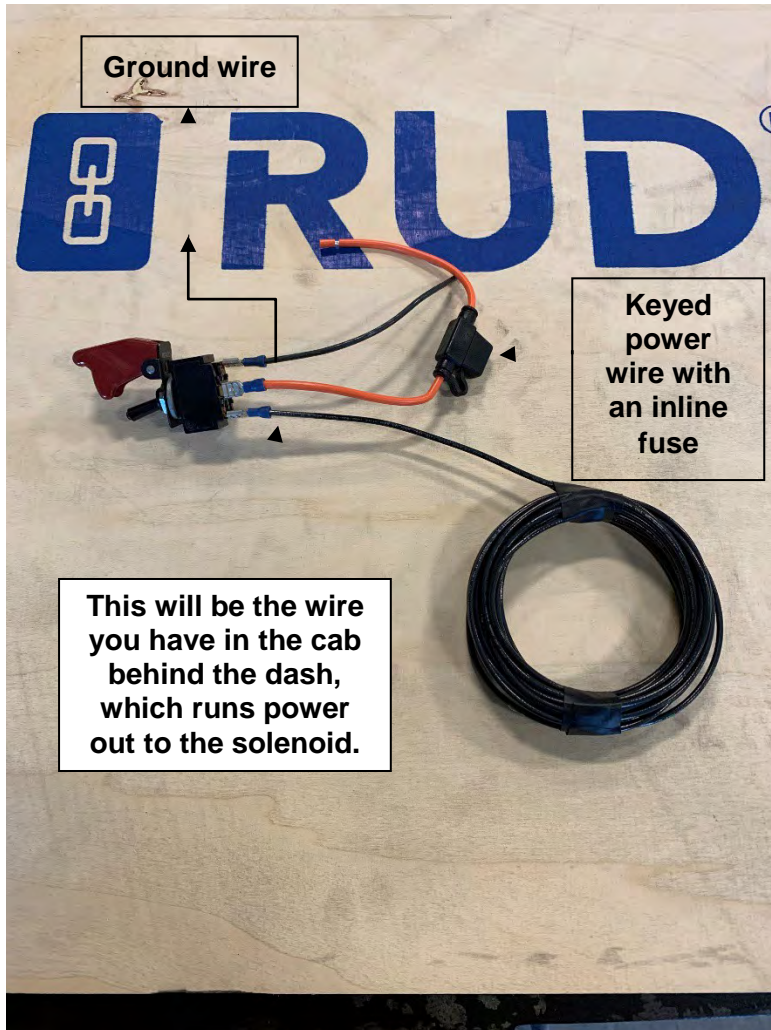

5. Once you have the entire airline ran you will need to run the wire from the solenoid to the cab, and up to the dash. Next, install a switch in the dash. When mounting the switch you will need to find a keyed power source to supply power to the switch, and you will need to run a ground wire for the switch. When you have a proper ground, the switch will light up red when turned on. After you have power to the switch in the dash, now use the wire you ran from the solenoid, and hook it up to the switch as shown below.

6. After you have, everything ran and working properly go back, zip tie all the wires, and airline up so nothing catches it. Please look at the next page for more information on the pneumatics.

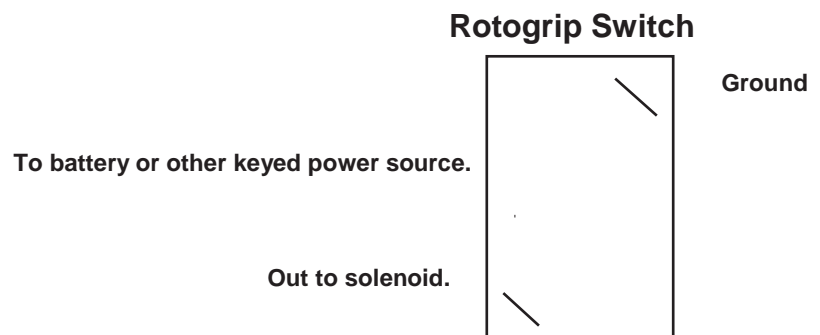

Installation Instructions

Pneumatic Kit Components

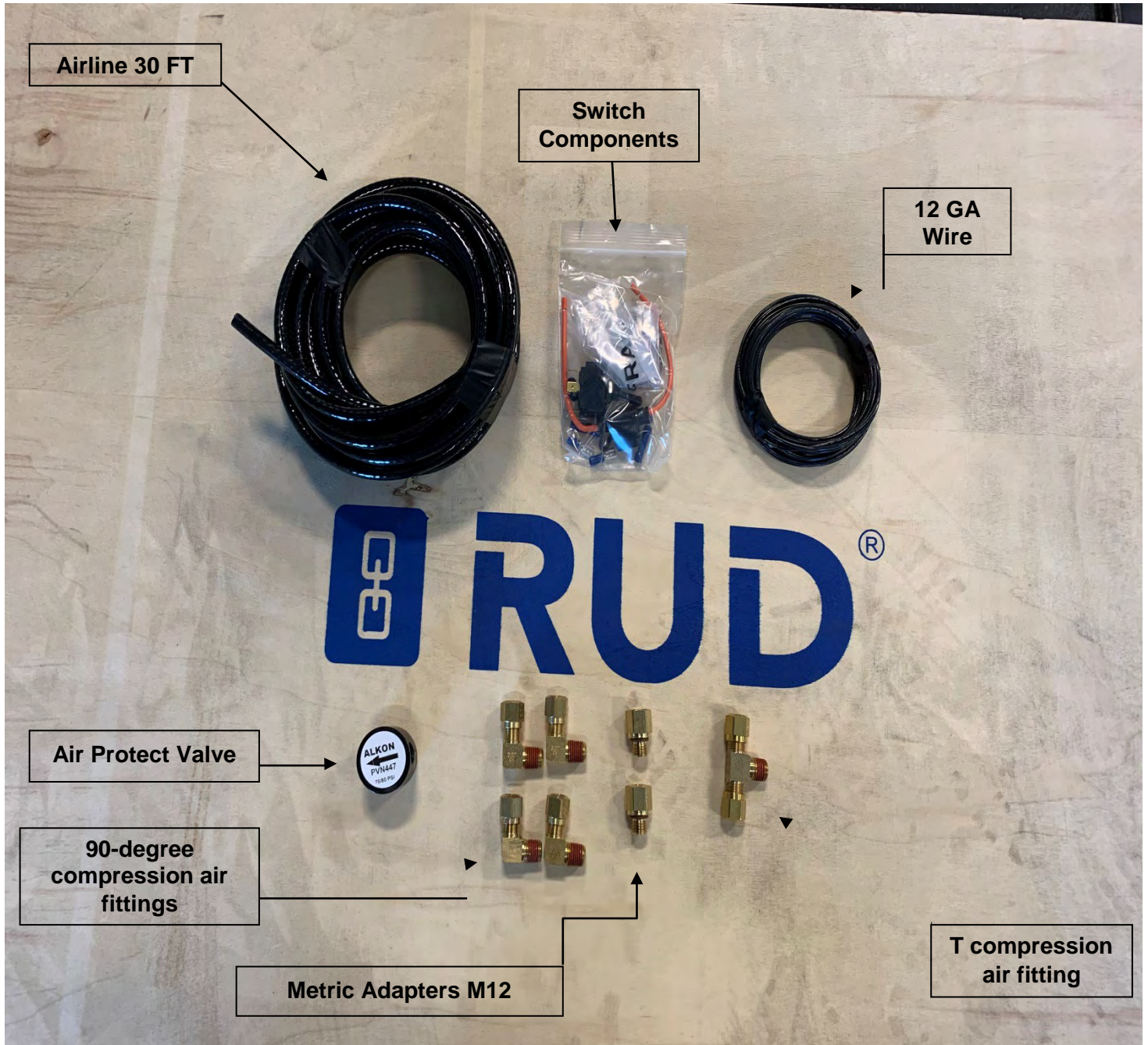



PNEUMATIC DIAGRAM

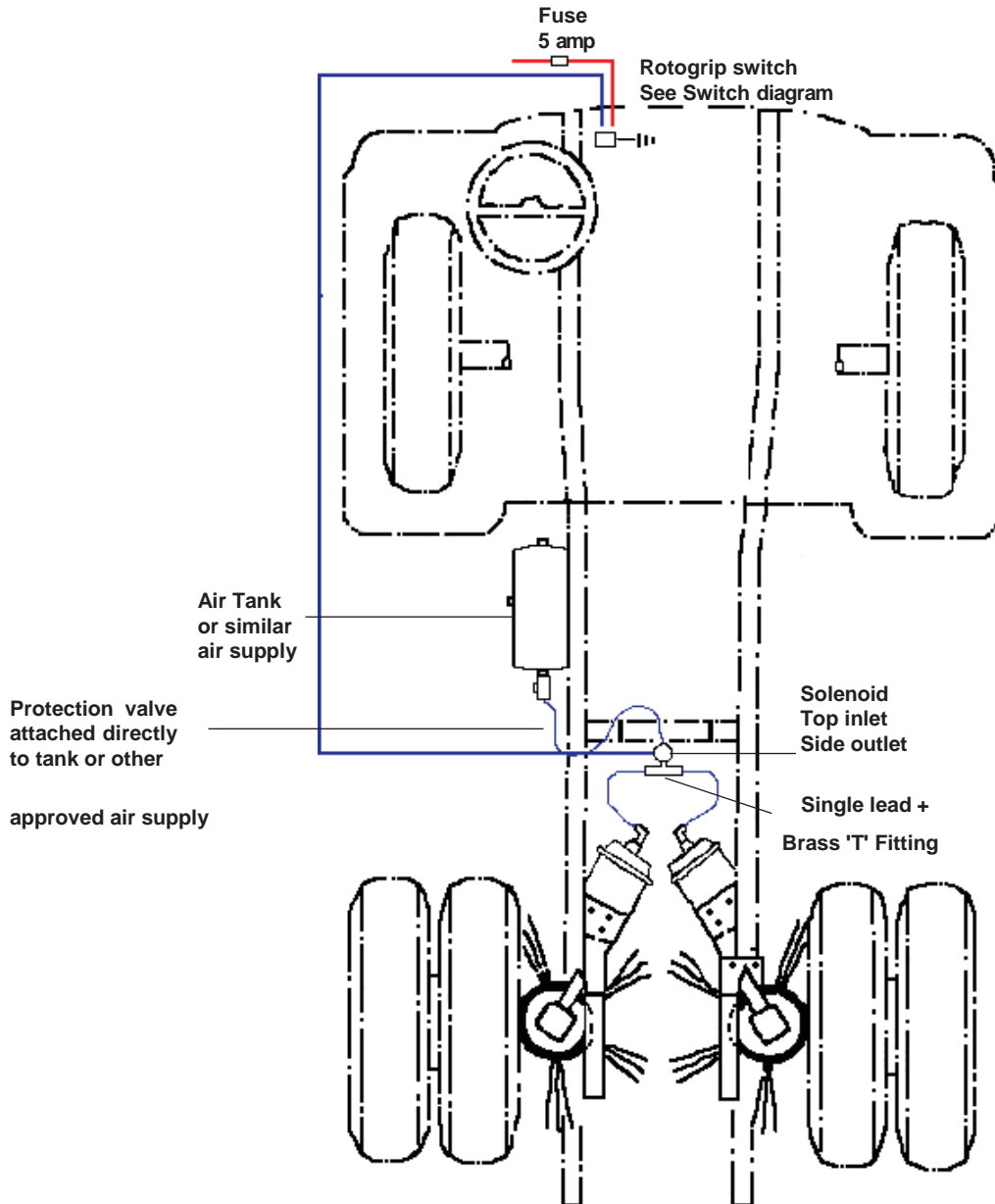

*Air supply, solenoid & airline configuration will vary depending on vehicle.

**When installing Rotogrip system on vehicle without its own air supply add-on compressor may be needed.

*** Make sure to leave loop in airline so that you have room for the axle to move up and down and not ruin the airline.

